

NUMBER: SB 500-21-009, Rev A
MODEL: ECLIPSE EA500
SUBJECT: Gearbox Venting Improvement

Mandatory

www.ECLIPSE.aero

1. PLANNING INFORMATION

A. Effectivity

Aircraft Serial Numbers: 000001 through 000262, 000266, and 000267 post MB 500-21-001 (Revisions A, B, C, or D) VCS Compressor Assembly Replacement.

B. Reason

This Service Bulletin improves the performance of the gearbox venting on the GDCA.

C. Description

This Service Bulletin removes the hose, vent cover, and vent valve to prevent oil leakage.

D. Relevant Publications

06-117751 – EA500 AMM, current revision

E. Compliance

Eclipse Aerospace Inc. considers this to be a single, mandatory action that should be accomplished no later than the next 300 Hour/24 month Inspection.

F. Approval

This Service Bulletin contains no modification information that revises the approved configuration and therefore does not require governmental or other regulatory agency approval.

G. Labor Requirements

The following information is for planning purposes only.

(1) Estimated labor hours to perform:

Suggested number of personnel: 1

Job Setup/Closeup: 0.5 hour

Modification: 1.0 hour

Total labor hours: 1.5 hours

The above is an estimate based on properly equipped and experienced personnel complying with this Service Bulletin. Actual labor hours may vary depending on workforce experience, concurrent maintenance, discovery of other discrepancies, etc.

(2) Qualification of personnel:

- A person properly authorized under 14 CFR 43 to perform aircraft maintenance.

H. Weight and Balance Change

N/A

I. Electrical Load Data Change

N/A

J. Software Accomplishment Summary

N/A

K. References

06-117751 – EA500 AMM, current revision

06-117751-TR21-4 AMM Temporary revision, Gearbox Breather Improvement

L. Publications Affected

None

M. Export Control

These commodities, technology or software were exported from the United States in accordance with the Export Administration Regulations. These commodities, technology or software are intended for use only in the End User's country. An export license from the U.S. Department of Commerce may be required before these products can be re-exported, transferred, transshipped on a non-continuous voyage, or otherwise disposed of in any other country, either in their original form or after being incorporated into an end item. Diversion of this end-item or its use contrary to any applicable U.S. government license or to U.S. law is prohibited.

2. MATERIAL INFORMATION

A. Materials

Parts Removal:

Fig. Item	Part Number	Description	Note	Qty	Unit of Issue
1	1ZJU4	ELBOW	Remove and Discard	1	EA.
2	2188277	SPACER	Remove and Discard	1	EA.
3	2188279 ^[1] or 2188281 ^[2]	COVER	Remove and Discard	1	EA.
4	2188515	TUBE	Remove and Discard	1	EA.
5	2188527	GASKET	Remove and Discard	1	EA.
6	32-114432-2002	GROMMET	Remove and Discard	1	EA.
7	40-2556-G20	O-RING	Remove and Discard	1	EA.
8	MS28775-017	O-RING	Remove and Discard	1	EA.
9	MS35206-242	SCREW	Remove and Discard	2	EA.
10	MS5338-42	LOCK WASHER	Remove and Discard	2	EA.
11	NAS620C8L	WASHER	Remove and Discard	2	EA.
12	YA-8024	VENT VALVE	Remove and Discard	1	EA.

[1] 2188279 cover is installed on GDCA 2188131 Rev F, H and J.

[2] 2188281 cover is installed on GDA 2188131 Rev G.

Non-Kitted Parts: Non-kitted parts must be ordered separately.

Part Number	Description	Qty	Unit of Issue
2188027 ^{[1] [2]}	KIT, VENT COVER INSTALLATION	1	EA.
2188029 ^{[1] [3]}	KIT, VENT COVER INSTALLATION	1	EA.
2653 (Alt: 2654)	HEYCO DOME PLUG	1	EA.

[1] Attaching hardware and gasket included in kit.

[2] Used on GDCA P/N 2188131 Rev F and G.

[3] Used on GDCA P/N 2188131 Rev H and J.

B. Consumables

Nomenclature	Specification	Use
Silicone Adhesive	RTV 106	Plug Sealant
Loctite 242	as needed	Attaching Hardware

C. Tooling

No special tooling required.

D. Cost

Contact Eclipse Aerospace Customer Care for cost information and availability.

E. Interchangeability/Intermixability of Parts

N/A

F. Part Re-identification

N/A

3. ACCOMPLISHMENT INSTRUCTIONS

A. Set Up

- (1) Make aircraft safe for maintenance. Refer to AMM 20-00-01- MAKE SAFE FOR MAINTENANCE.
- (2) Gain access to the VCS by removing 211 CT - Nose Access Panel. Refer to AMM-53-10-11-001-801 – Nose Access Panel - Removal.

B. Procedure

- (1) Clean off the sealant which held the tube to the grommet. Remove tube (2188515) and grommet (32-114432-2002), refer to [Figure 1](#).
- (2) Remove cover (2188279 or 2188281) with attached elbow (1ZJU4) and attaching hardware: screws (MS35206-242, X2), lock washers (MS35338-42, X2), and washers (NAS620C8L, X2), refer to [Figure 1](#).
- (3) From under the cover, remove the vent valve (YA-8024), o-ring (40-2556-G20), spacer (2188277), o-ring (MS28775-017), and gasket (2188527), refer to [Figure 1](#).
- (4) Clean up any oil found on top, bottom, or sides of the gearbox.
- (5) Install vent cover kit (2188027 or 2188029) with elbow installed, as shown, with gasket (2188293) and hardware as specified on [Figure 2](#), view "F". Apply Loctite 242 to screw thread and torque to 10–13in-lbs, refer to [Figure 2](#).
- (6) Install plug (2653) in existing grommet hole. Secure plug in hole by applying a fillet seal using RTV 106, refer to [Figure 2](#).

C. Close Up

- (1) Install 211 CT - Nose Access Panel. Refer to AMM-53-10-11-041-801 – Nose Access Panel - Installation.
- (2) If all other maintenance is complete, return aircraft to service. Refer to AMM 20-00-02-051-801 RETURN TO SERVICE (AFTER MAINTENANCE).

D. Limitations and Procedures

N/A

E. Parts Disposition

N/A

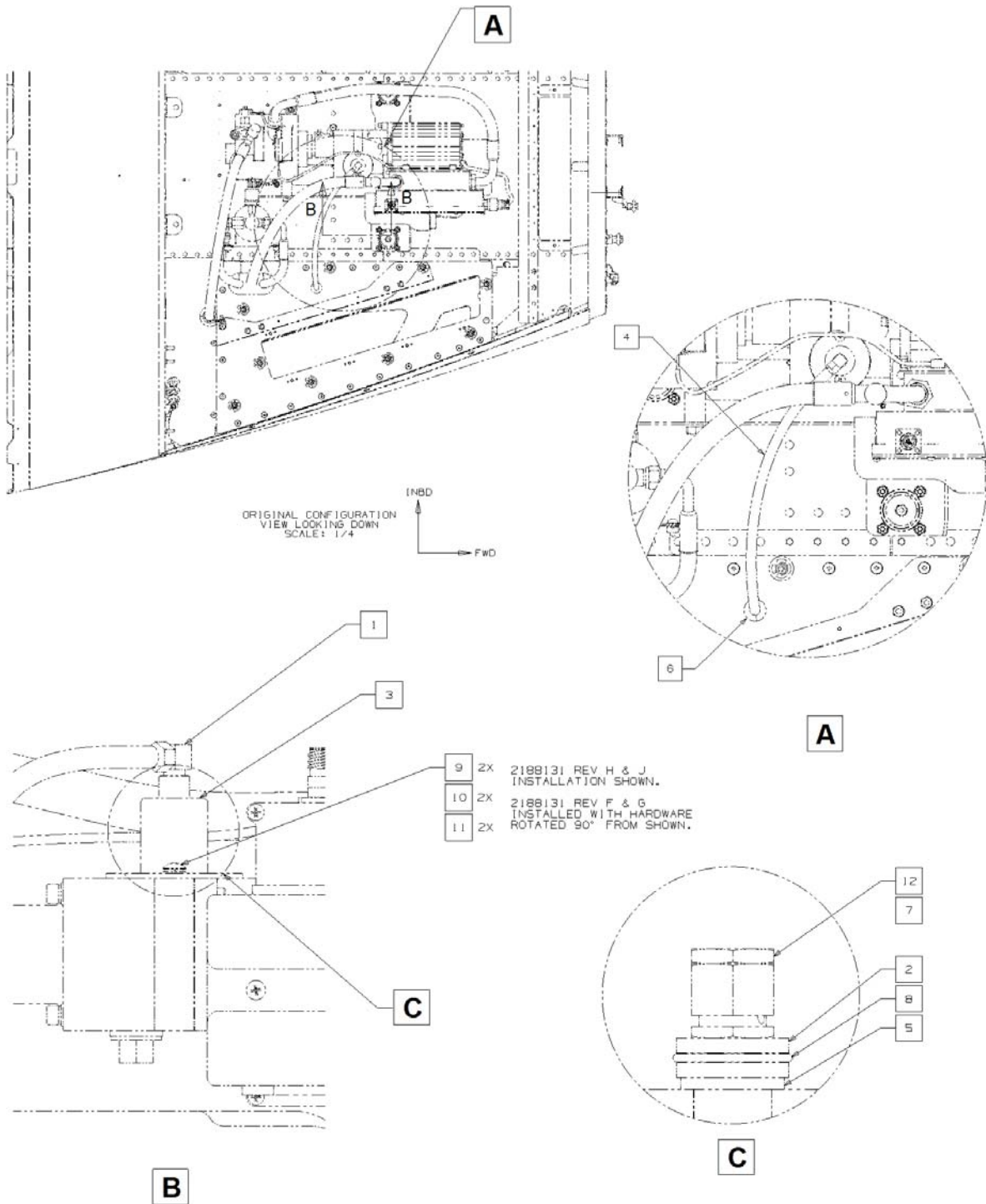

(ORIGINAL VIEW, PARTS REMOVAL)

5141879A

Figure 1. Parts Removal

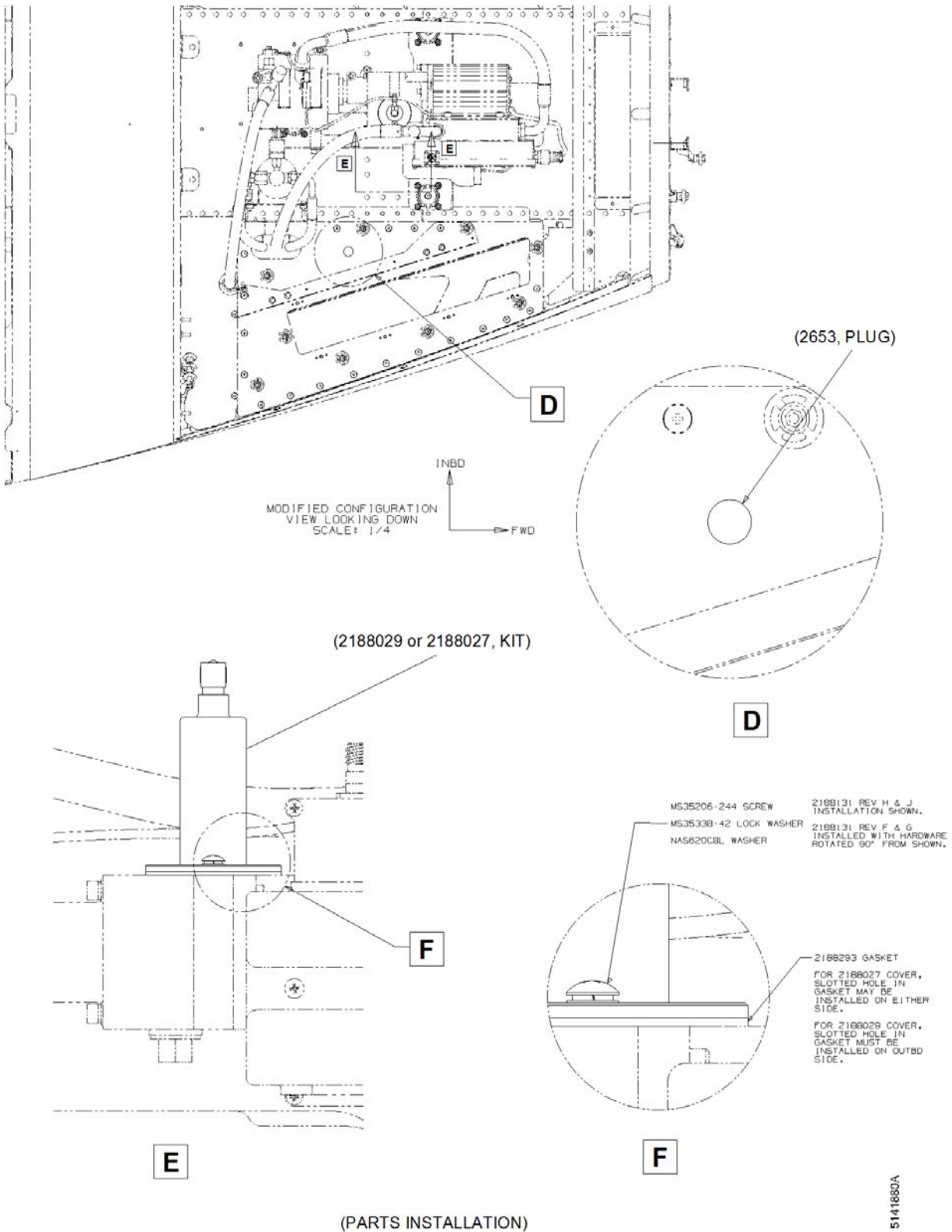

Figure 2. Parts Installation

4. PART MARKING

None.

5. RECORD OF COMPLIANCE

Upon completion of this Service Bulletin, make an appropriate maintenance-record entry specifying the Service Bulletin number.

6. NOTIFYING ECLIPSE AEROSPACE

On completing this service bulletin, the operator/maintainer shall complete the attached Compliance Record and send it to Eclipse Aerospace via regular mail, fax, or e-mail.

Mailing Address	Eclipse Aerospace Incorporated ATTN: Service Engineering 2503 Clark Carr Loop SE Albuquerque, NM 87106
Fax	1-505-241-8802
E-mail	sbcompliance@eclipse.aero

[Intentionally Blank Page]

